

19-1105/

REC'D 12345678910

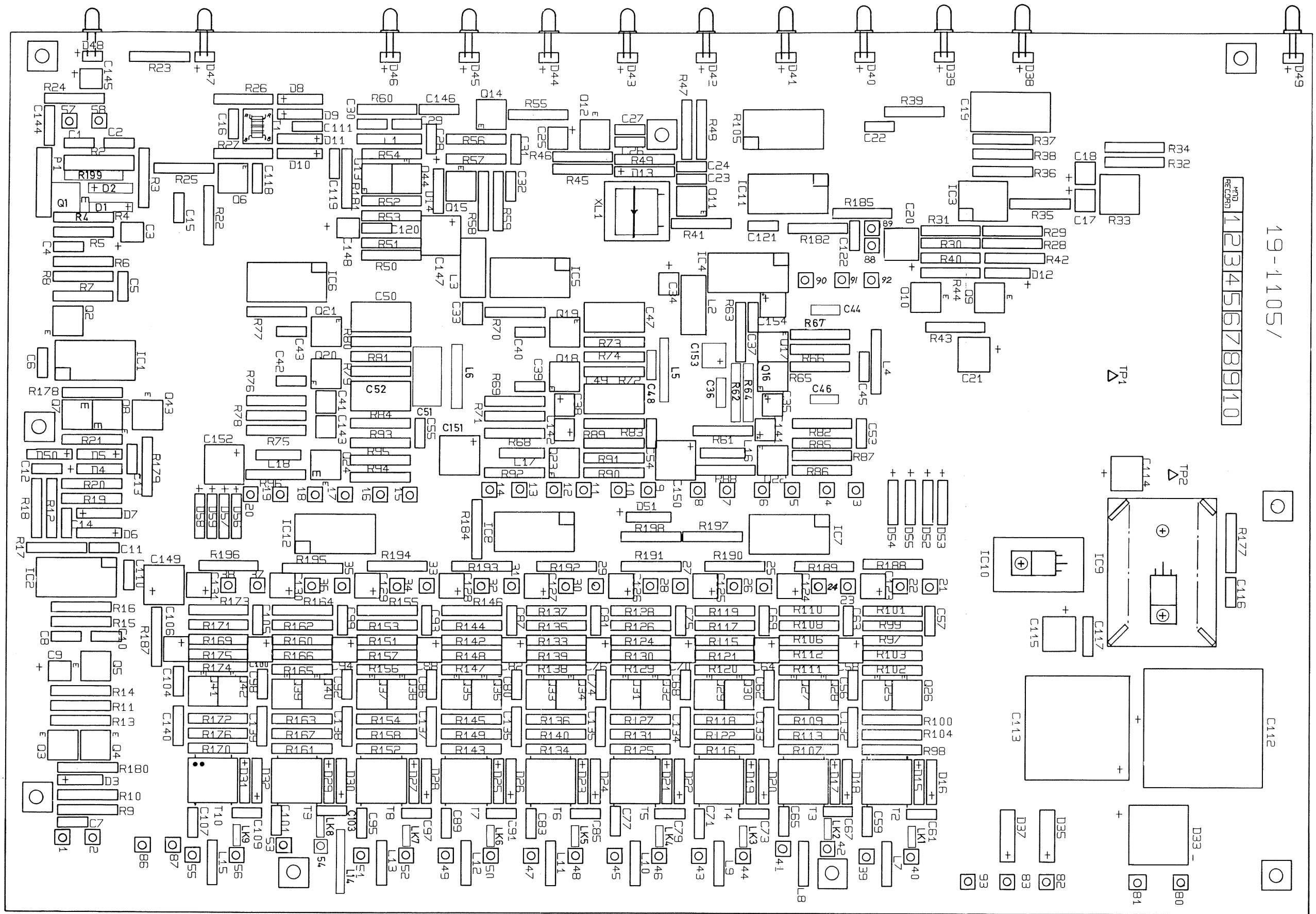

**Component Layout:
 Frequency Distribution Board 19-1105 Fic**

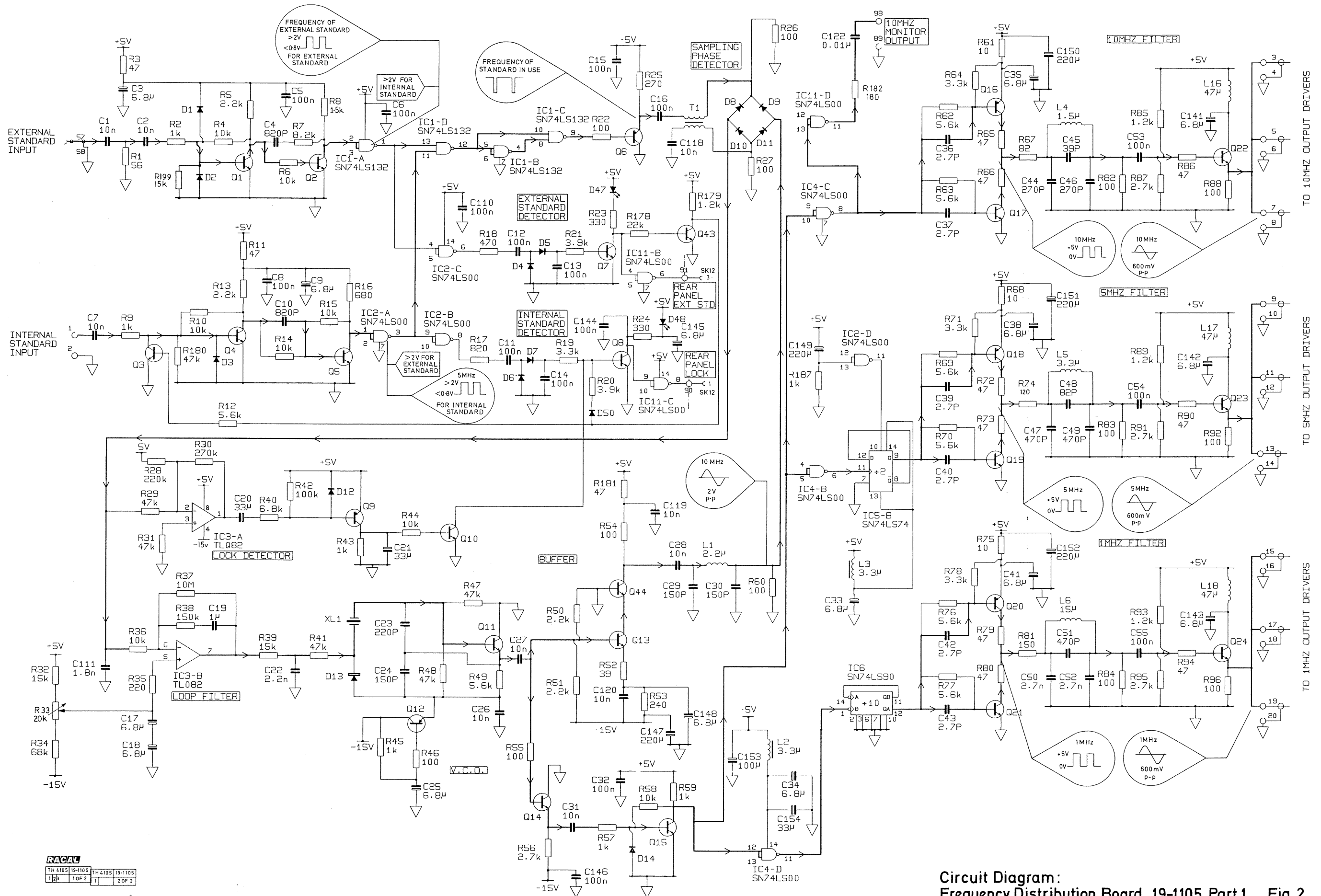

| | | | |
|---------|---------|---------|---------|
| RACAL | | | |
| TH 4105 | 19-1105 | TH 4105 | 19-1105 |
| 1/2b | 10F 2 | 1 | 20F 2 |

Circuit Diagram: Frequency Distribution Board 19-1105 Part 1 Fig.2

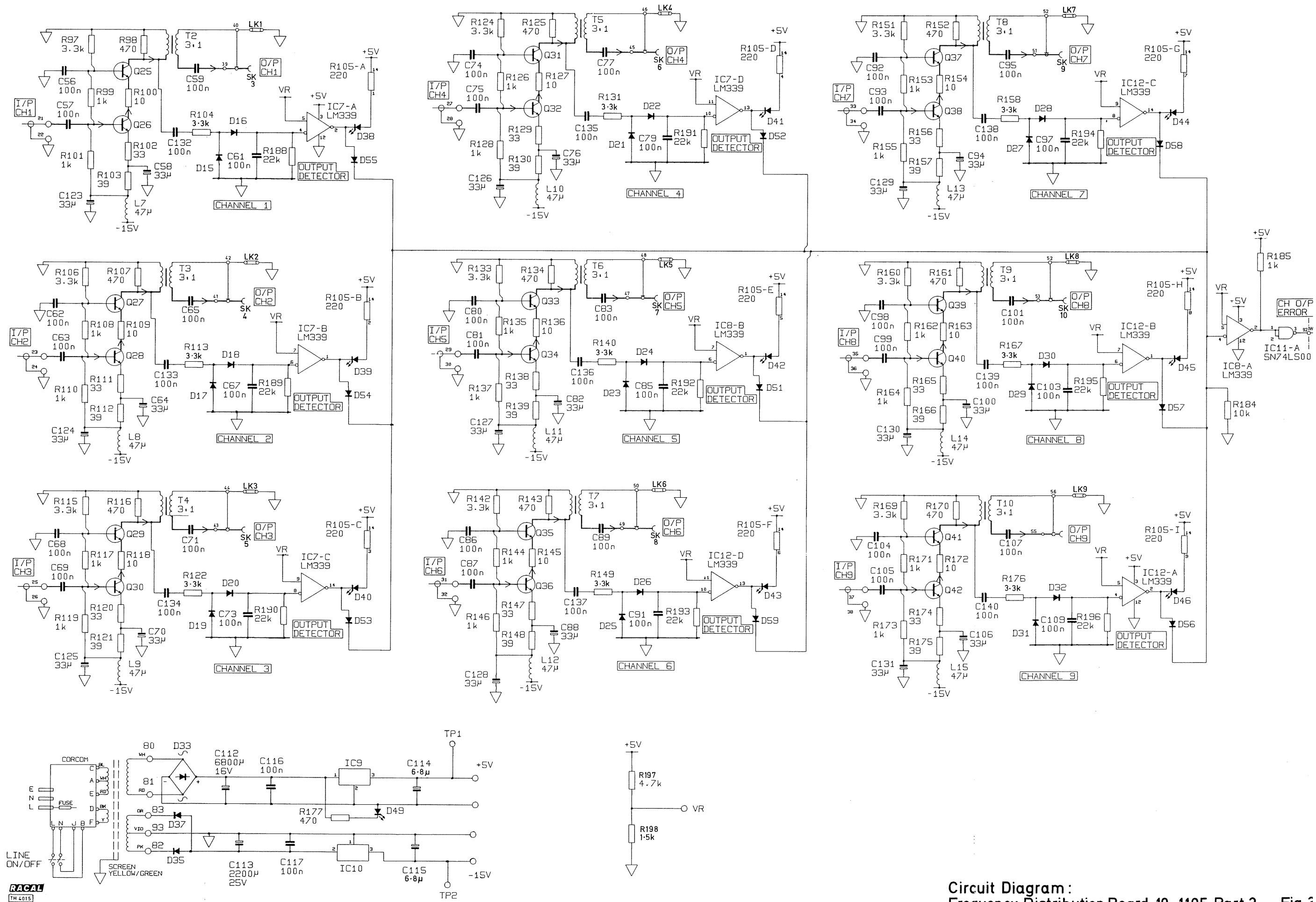

Circuit Diagram:
Frequency Distribution Board 19-1105 Part 2 Fig.3